

SPECIFICATIES

LJUNGBY L9

TIER V MOTOR



Foto: Lars Malm 201901
780036-59 REV 1



SUPERIOR PERFORMANCE

- OPLOSSING NAAR UW BEHOEFTE ■ KRACHTIGE MILIEUBEWUSTE MOTOREN
- LAGE TOTALE KOSTEN ■ LAAGSTE GELUIDSNIVEAU OP DE MARKT
- UNIEK LAADFRAME ■ BETROUWBAAR EN ONDERHOUDSVRIENDELIJK





SPECIFICATIES | LJUNGBY L9

S = standaard

O = optie

AANDRIJFLIJN

Motor	Sisu 66 LFTN
Max. vermogen	151/205
Max. koppel	940
Transmissie	ZF Ergopower WG160
Vooras	ZF MTL 3075
Achteras	ZF MTL 3075
Automatische limited slip achter	S
Auto / manueel diff lock voor	S
Dual - circuit hydraulisch rempedaal	S
Hydraulisch bediende handrem	S
Lock-up transmissie	O
Omkeerbare ventilator	O

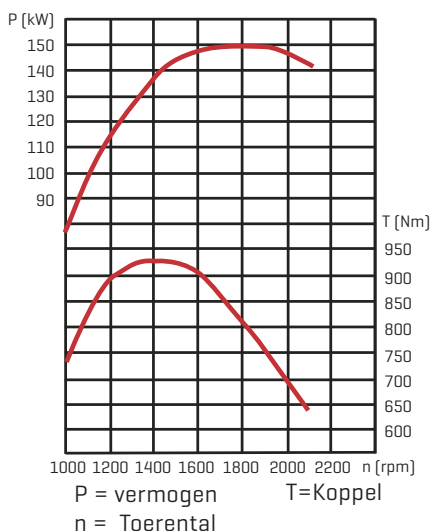

KRACHT EN GEWICHT

Opbrekkracht [KN]		95
Kantelmoment [kg]	0°	6500
	40°	5750
	45°	5500
Werkgewicht [tonnen]		9,5-10,5
Standaard bak [m3]		1,8
Licht materiaal bak [m3]		4,0
Houtklem [m2]		1,6

HYDRAULISCH SYSTEEM

Hydraulische pomp	Parker
Flow [l/min bij 2100 rpm]	220
Druk [bar]	240
Hefcilinder [mm]	56/110
Hefcilinder slag [mm]	850
Dumpcilinder [mm]	56/100
Dumpcilinder slag [mm]	895
Hydrauliekoeling	S

STUURSYSTEEM

Draaihoek	45
Stuurcilinder [mm]	40/70
Stuurcilinder slag [mm]	557
Pendelen achteras [graden]	+/-15

WIELEN

Radiaal banden	S
Afmetingen	17,5R25

AFMETINGEN

A	6970
B	3000
C	1555
D	375
E	3985
F	2645
G	1050
H	3205
I	2310
J	2620
R1	4940
R2	5630

ELEKTRISCH SYSTEEM

Batterij	2 x 12 V, 120 A
Dynamo	100 A

INHOUD INFORMATIE

Koelsysteem [l]	30
Motor [l]	29
Hydraulisch systeem [l]	175
Brandstoftank [l]	210
Ad Blue tank [l]	60

Afmetingen verwijzen naar figuur beneden [mm]

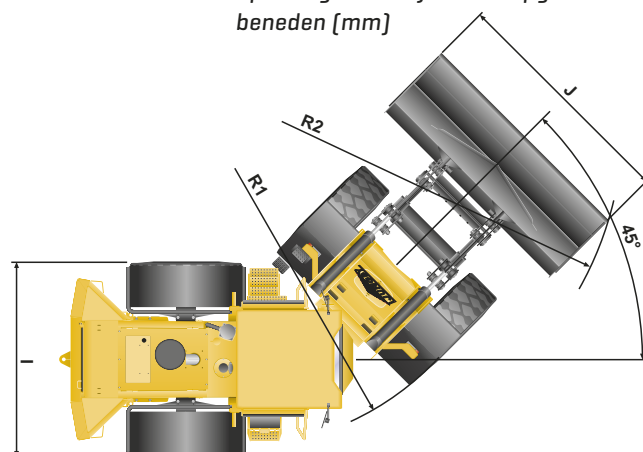
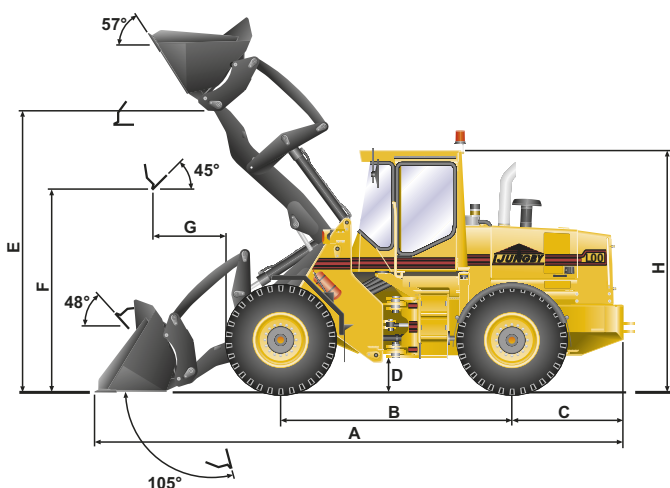

Wijzigingen voorbehouden