

SPECIFICATIES

LJUNGBY L15

TIER V MOTOR



Foto: Lars Malm ©2019, 01
790036-66 Rev.1



SUPERIOR PERFORMANCE

- OPLOSSING NAAR UW BEHOEFTE ■ KRACHTIGE MILIEUBEWUSTE MOTOREN
- LAGE TOTALE KOSTEN ■ LAAGSTE GELUIDSNIVEAU OP DE MARKT
- UNIEK LAADFRAME ■ BETROUWBAAR EN ONDERHOUDSVRIENDELIJK





SPECIFICATIES | LJUNGBY L15

S = standaard

O = optie

AANDRIJFLIJN

Motor	Sisu 66 LFTN
Max. vermogen	157/213
Max. koppel	945
Transmissie	ZF Ergopower WG190
Vooras	ZF MTL 3085
Achteras	ZF MTL 3085
Automatische limited slip achter	S
Auto / manueel diff lock voor	S
Dual - circuit hydraulisch rempedaal	S
Hydraulisch bediende handrem	S
Lock-up transmissie	O
Omkeerbare ventilator	O

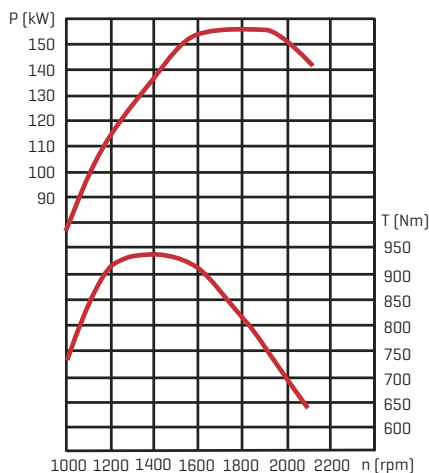

P = vermogen
n = Toerental
T = Koppel

KRACHT EN GEWICHT

Opbrekkracht [KN]	120
Kantelmoment [kg]	0° 10900
	40° 9350
	45° 9100
Werkgewicht [tonnen]	14,5-16,0
Standaard bak [m3]	2,7
Licht materiaal bak [m3]	8,0
Houtklem [m2]	2,0

WIELEN

Radiaal banden	S
Afmetingen	20,5R25

HYDRAULISCH SYSTEEM

Hydraulische pomp	Parker
Flow [l/min bij 2100 rpm]	304
Druk [bar]	250
Hefcilinder [mm]	60/115
Hefcilinder slag [mm]	925
Dumpcilinder [mm]	60/115
Dumpcilinder slag [mm]	895
Hydrauliekoeling	S

STUURSYSTEEM

Draaihoek	45
Stuurcilinder [mm]	40/80
Stuurcilinder slag [mm]	557
Pendelen achteras [graden]	+/-15

AFMETINGEN

A	7400
B	3100
C	1635
D	430
E	4180
F	2660
G	1160
H	3310
I	2535
J	2800
R1	5090
R2	5950

ELEKTRISCH SYSTEEM

Batterij	2 x 12 V, 120 A
Dynamo	100 A

INHOUD INFORMATIE

Koelsysteem [l]	30
Motor [l]	29
Hydraulisch systeem [l]	195
Brandstoftank [l]	210
Ad Blue tank [l]	60

Afmetingen verwijzen naar figuur beneden [mm]

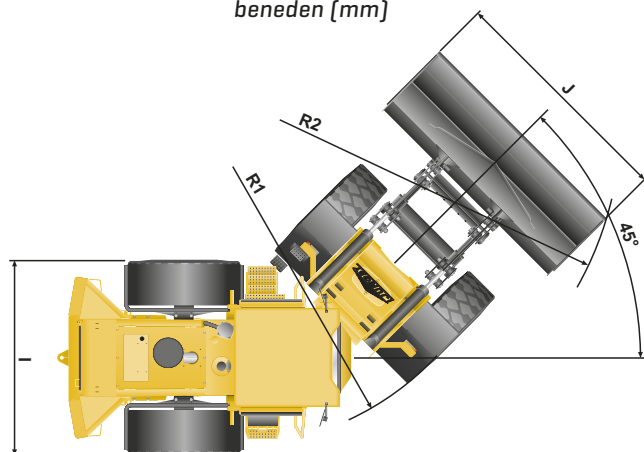
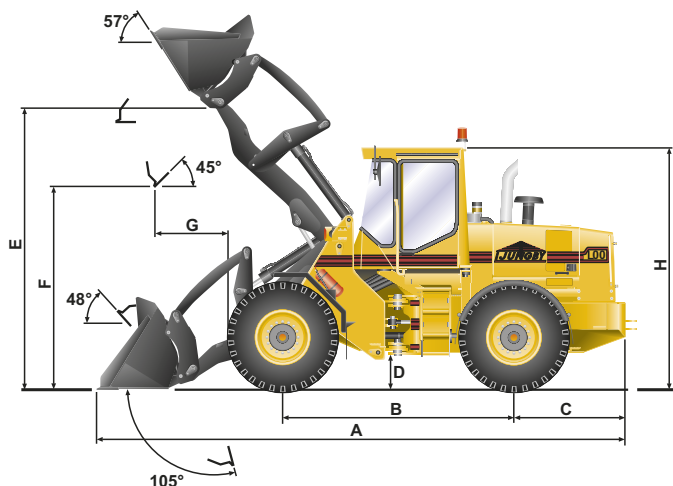

Wijzigingen voorbehouden