

SPECIFICATIES

# LJUNGBY L18

TIER V MOTOR



Foto: Lars Malm ©2019, 01  
790436-63 Rev.1



SUPERIOR PERFORMANCE

- OPLOSSING NAAR UW BEHOEFTE ■ KRACHTIGE MILIEUBEWUSTE MOTOREN
- LAGE TOTALE KOSTEN ■ LAAGSTE GELUIDSNIVEAU OP DE MARKT
- UNIEK LAADFRAME ■ BETROUWBAAR EN ONDERHOUDSVRIENDELIJK





## SPECIFICATIES | LJUNGBY L18

S = standaard

O = optie

### AANDRIJFLIJN

Motor	Sisu 74 LFTN
Max. vermogen	220/300
Max. koppel	1200
Transmissie	ZF Ergopower WG210
Vooras	ZF MTL 3095
Achteras	ZF MTL 3085
Automatische limited slip achter	S
Auto / manueel diff lock voor	S
Dual - circuit hydraulisch rempedaal	S
Hydraulisch bediende handrem	S
Omkeerbare ventilator	O

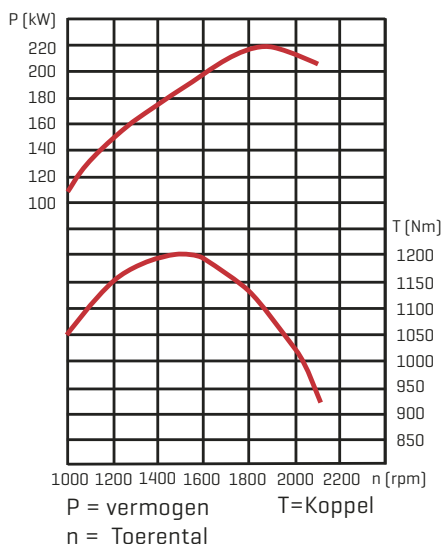

### KRACHT EN GEWICHT

Opbrekkracht [KN]	170
Kantelmoment [kg]	0° 13900
	40° 13100
	45° 12900
Werkgewicht [tonnen]	17,2-19,0
Standaard bak [m3]	3,5
Licht materiaal bak [m3]	10,0
Houtklem [m2]	2,6

### HYDRAULISCH SYSTEEM

Hydraulische pomp	Parker/Sauer
Flow [l/min bij 2100 rpm]	400
Druk [bar]	270
Hefcilinder [mm]	70/130
Hefcilinder slag [mm]	980
Dumpcilinder [mm]	70/130
Dumpcilinder slag [mm]	880
Hydrauliekoeling	S

### STUURSYSTEEM

Draaihoek	45
Stuurcilinder [mm]	40/80
Stuurcilinder slag [mm]	557
Pendelen achteras [graden]	+/-15

### WIELEN

Radiaal banden	S
Afmetingen	23,5R25

### ELEKTRISCH SYSTEEM

Batterij	2 x 12 V, 120 A
Dynamo	100 A

### INHOUD INFORMATIE

Koelsysteem [l]	30
Motor [l]	29
Hydraulisch systeem [l]	195
Brandstoftank [l]	310
Ad Blue tank [l]	60

### AFMETINGEN

A	7980
B	3300
C	1920
D	435
E	4265
F	2775
G	1240
H	3430
I	2600
J	3040
R1	5300
R2	6080

Afmetingen verwijzen naar figuur beneden [mm]

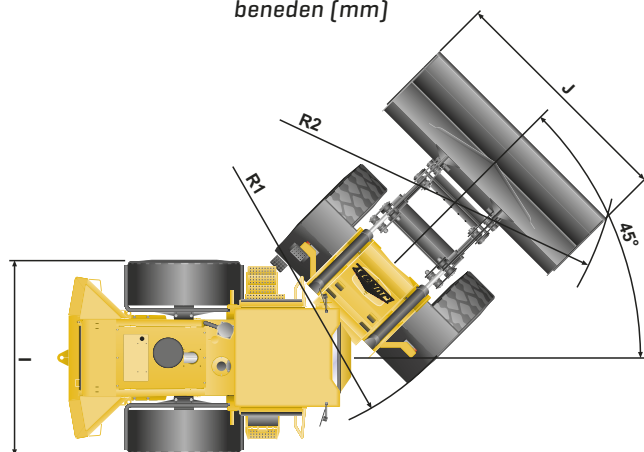
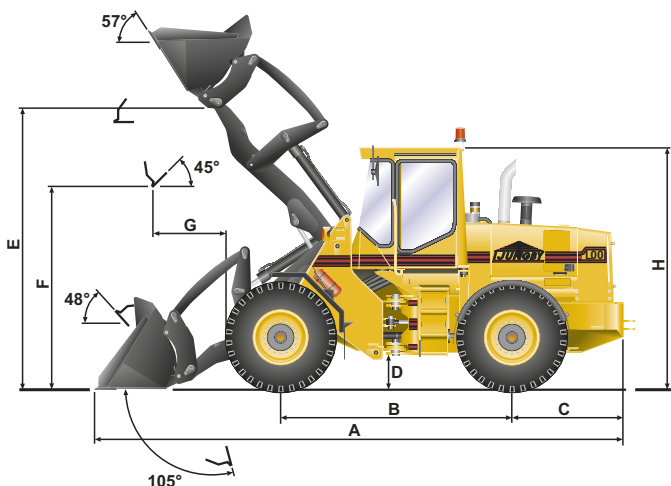

Wijzigingen voorbehouden